

A3MS (SAE2) Bent Axis Motors -2022-

High Pressure Hydraulic Bent Axis Piston Motors, High Pressure, 450/500 BAR Working Pressure. High Rotational Speed, High Efficiency, Slim Design, Cast Iron Motor Body, Re-Designed in 2022.

Designation;

12cc, 18cc, 25cc, 32cc, 41cc,
50cc, 56cc, 63cc,

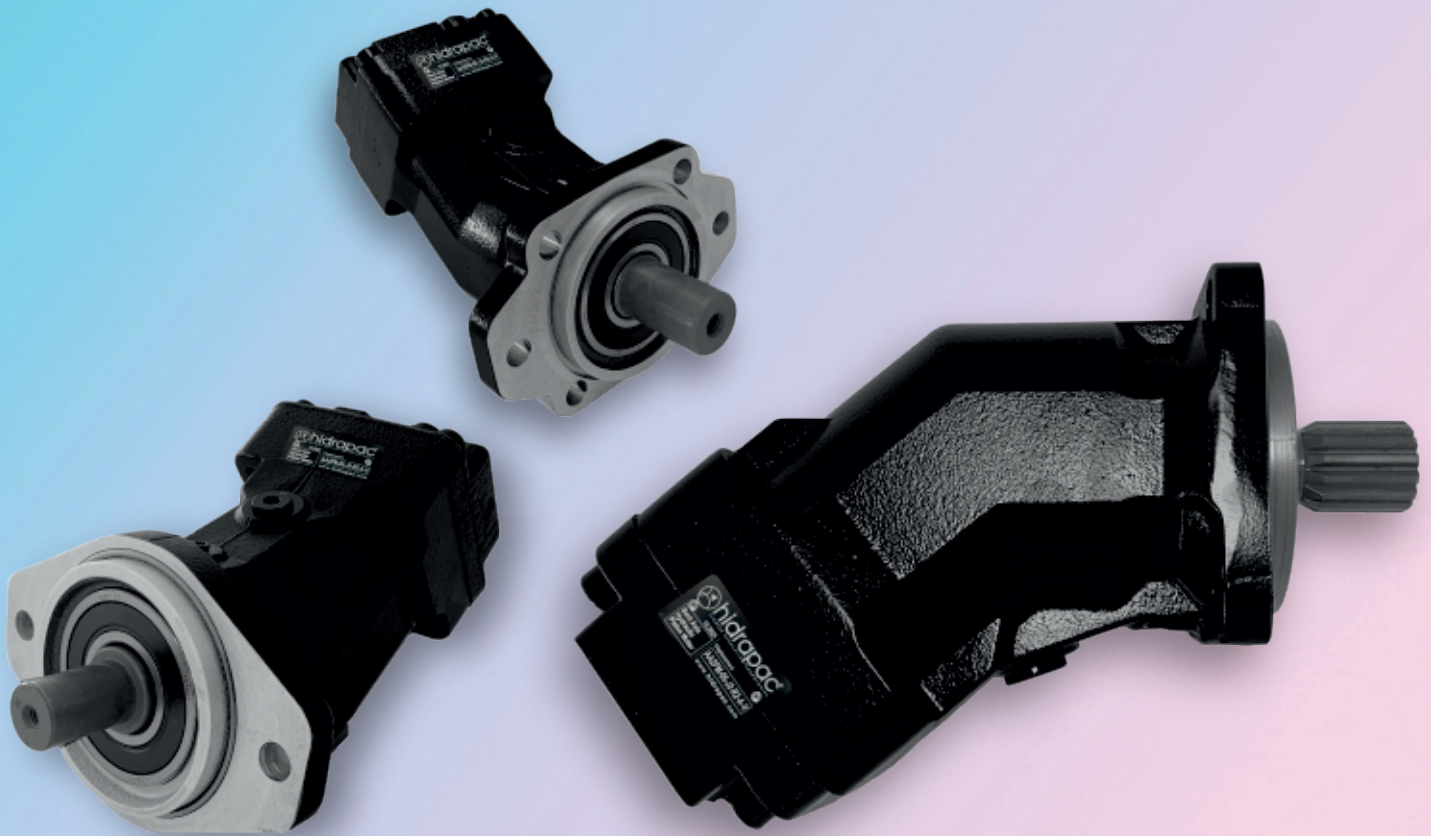

Hidrapac **Store**

www.HIDRAPAC.com.tr

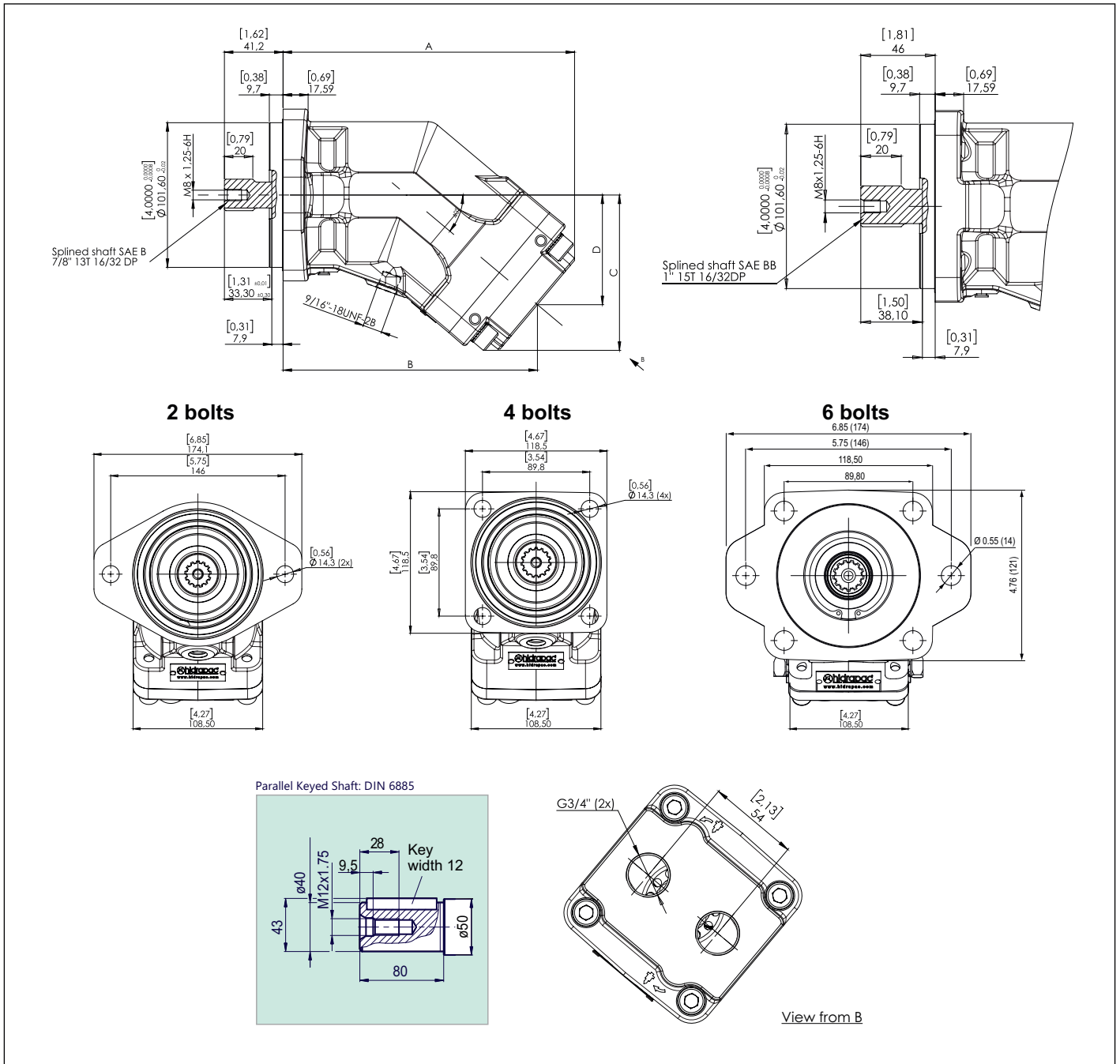

MOTOR MODEL	DISPL. (cc)	A	B	C	D	SHAFT (SPLINED)	SHAFT (KEYED)
12 cc (SAE J744)	12.1	197.2	172.5	103.7	73.0	SAE B 7/8"13T-16/32DP	Parallel Keyed Shaft: DIN 6885
18 cc (SAE J744)	18.0	197.2	172.5	103.7	73.0	SAE B 7/8"13T-16/32DP	Parallel Keyed Shaft: DIN 6885
25 cc (SAE J744)	25.1	197.2	172.5	103.7	73.0	SAE B 7/8"13T-16/32DP	Parallel Keyed Shaft: DIN 6885
32 cc (SAE J744)	32.0	203.2	178.5	108.7	77.0	SAE B 7/8"13T-16/32DP	Parallel Keyed Shaft: DIN 6885
41 cc (SAE J744)	41.2	203.2	178.5	108.7	77.0	SAE B 7/8"13T-16/32DP	Parallel Keyed Shaft: DIN 6885
50 cc (SAE J744)	50.2	214.7	190.0	118.2	86.5	SAE BB 1" 15T-16/32DP	Parallel Keyed Shaft: DIN 6885
56 cc (SAE J744)	56.0	214.7	190.0	118.2	86.5	SAE BB 1" 15T-16/32DP	Parallel Keyed Shaft: DIN 6885
63 cc (SAE J744)	63.3	214.7	190.0	118.2	86.5	SAE BB 1" 15T-16/32DP	Parallel Keyed Shaft: DIN 6885

Characteristics of the A3MS - SAE2 Flange Bent Axis Motors

MOTOR MODEL	DISPL. (cc)	CONTINUOUS MAX. SPEED (rpm)	INTERMITTENT MAX. SPEED (rpm)	MAX. FLOW ABSORBED (l/mn)	TORQUE BAR (m.N/bar)	TORQUE AT 350 BAR (m.N)	MOTOR MAX./MIN. TEMP. (celsius)	MAX. ALLOW PRESSURE CONTN./PEAK (bar)
12 cc	12.1	8000	8800	96	0.19	66	-25 / 110	400 / 450
18 cc	18.0	8000	8800	144	0.28	98	-25 / 110	400 / 450
25 cc	25.1	6300	6900	158	0.40	140	-25 / 110	400 / 450
32 cc	32.0	6300	6900	202	0.50	175	-25 / 110	400 / 450
41 cc	41.2	5600	6200	230	0.65	227	-25 / 110	400 / 450
50 cc	50,2	5000	5500	252	0.80	280	-25 / 110	400 / 450
56 cc	56,0	5000	5500	280	0.90	320	-25 / 110	400 / 450
63 cc	63.3	5000	5500	315	1.00	350	-25 / 110	400 / 450

Direction of Rotation; Reversible

The motors rotate clockwise or counter-clockwise depending on the direction of hydraulic flow entering the motor.

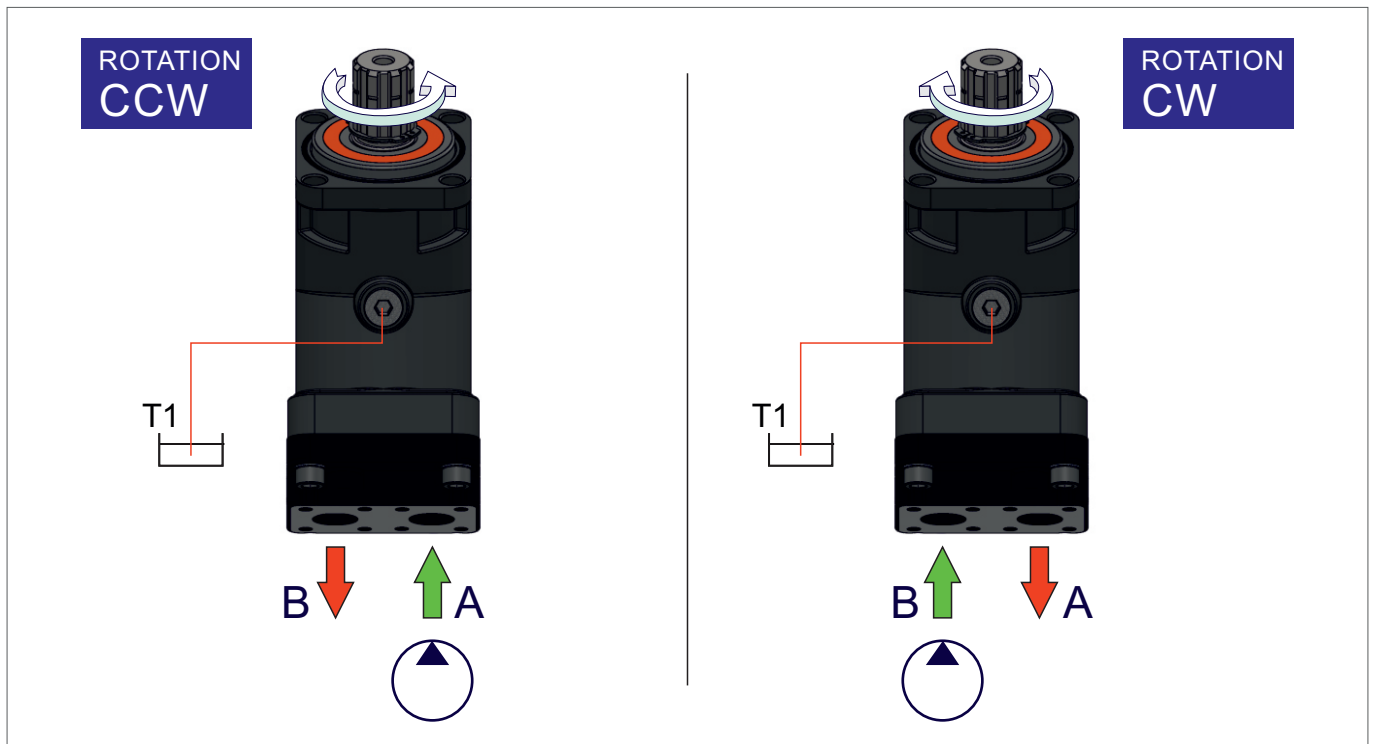

Ordering Code; A3MS - SAE2 Flange Bent Axis Motors

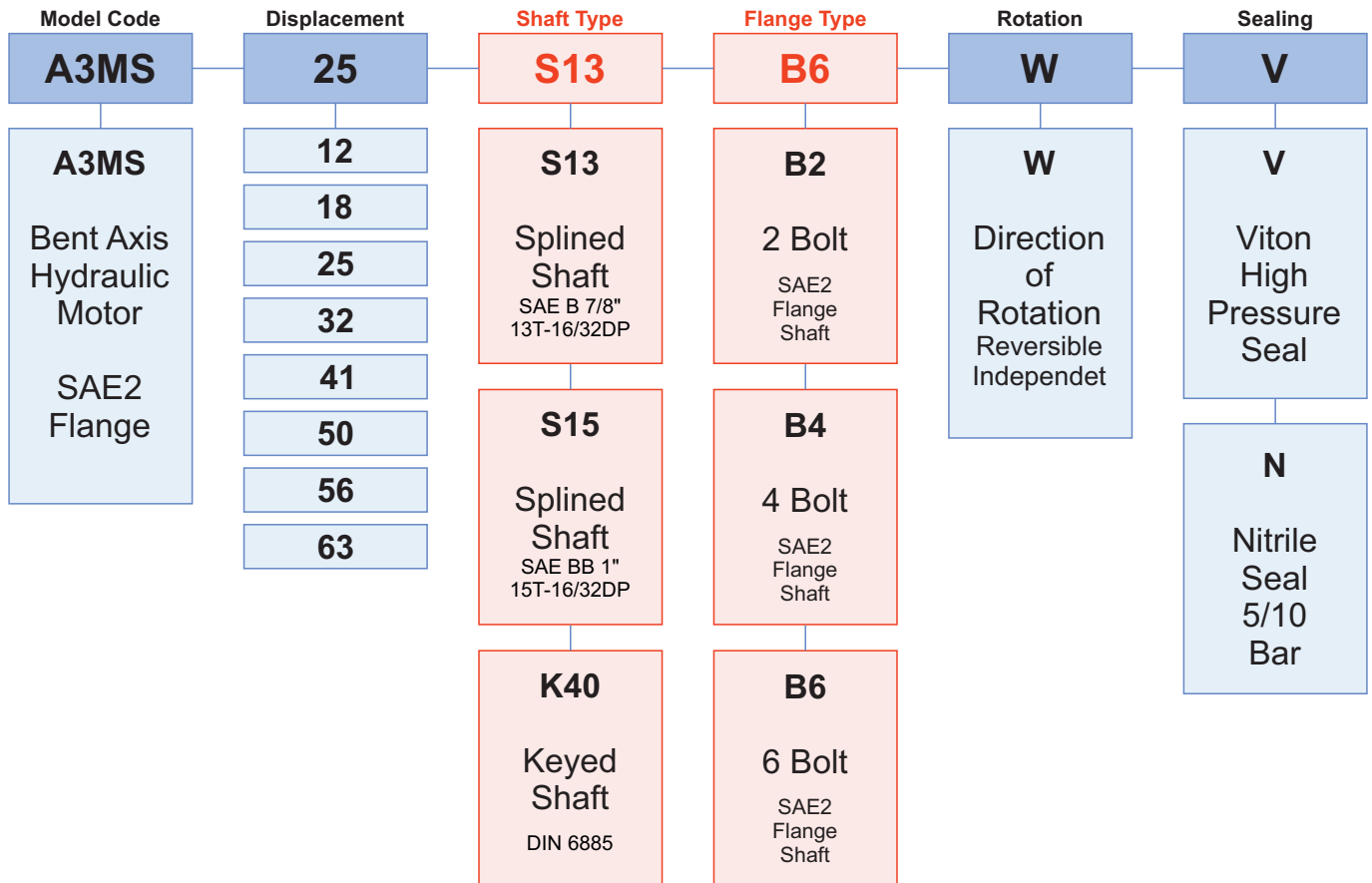

Formulas			
Pump Output Flow	GPM	$GPM = (\text{Speed (rpm)} \times \text{disp. (cu. in.)}) / 231$	$GPM = (n \times d) / 231$
Pump Input Horsepower	HP	$HP = GPM \times \text{Pressure (psi)} / 1714 \times \text{Efficiency}$	$HP = (Q \times P) / 1714 \times E$
Pump Efficiency	E	Overall Efficiency = Output HP / Input HP	Eoverall = HPOut / HPIn X 100
		Overall Efficiency = Volumetric Eff. x Mechanical Eff.	EOverall = EffVol. x EffMech.
Pump Volumetric Efficiency	E	Volumetric Efficiency = Actual Flow Rate Output (GPM) / Theoretical Flow Rate Output (GPM) x 100	EffVol. = QAct. / QTheo. X 100
Pump Mechanical Efficiency	E	Mechanical Efficiency = Theoretical Torque to Drive / Actual Torque to Drive x 100	EffMech = TTheo. / TAct. x 100
Pump Displacement	CIPR	Displcmnt (In.3 / rev.) = Flow Rate (GPM) x 231 / Pump RPM	CIPR = GPM x 231 / RPM
Pump Torque	T	Torque = Horsepower x 63025 / RPM	T = 63025 x HP / RPM
		Torque = Pressure (PSIG) x Pump Displacement (CIPR) / 2π	T = P x CIPR / 6.28

- Horsepower for driving a pump** : For every 1 hp of drive, the equivalent of 1 gpm @ 1500 psi can be produced.
- Horsepower for idling a pump** : To idle a pump when it is unloaded will require about 5% of it's full rated power
- Wattage for heating hydraulic oil** : Each watt will raise the temperature of 1 gallon of oil by 1° F. per hour.
- Flow velocity in hydraulic lines** : Pump suction lines 2 to 4 feet per second, pressure lines up to 500 psi - 10 to 15 ft./sec., pressure lines 500 to 3000 psi - 15 / 20 ft./sec.; all oil lines in air-over-oil systems; 4 ft./sec.

Installation & Assemble Informations for Bent Axis Motors

POSITION

DIN Flange Bent Axis Motors can be operate any position.

DIRECTION OF ROTATION

DIN Flange Bent Axis Motors can be operate in both directions of rotation.

Before of Installation operation, the motor must be filled with hydraulic fluid and air bled.

INSTALLATION POSITION

See following examples.

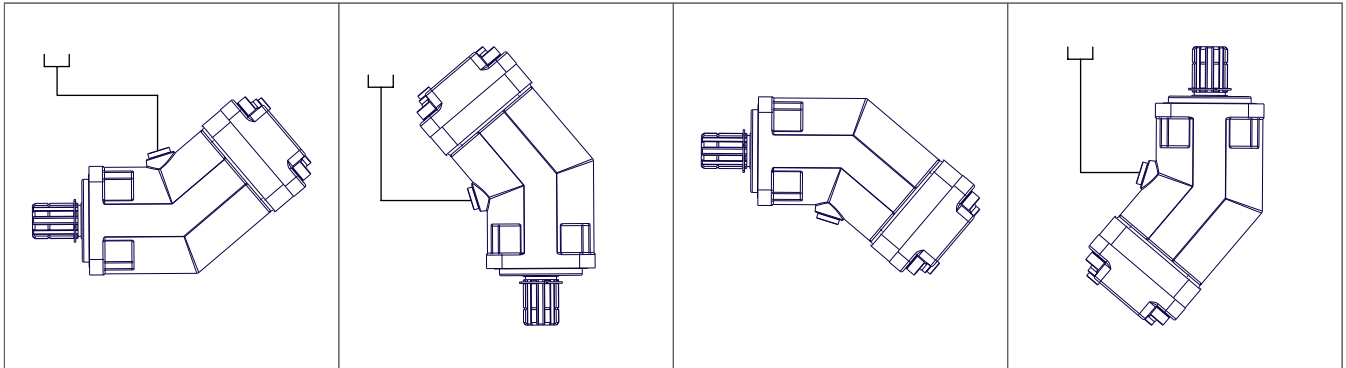

HYDRAULIC FLUID

Recommended ;

Generally : between 15 and 200 cSt.

Maximum : between 5 and 1600 cSt.

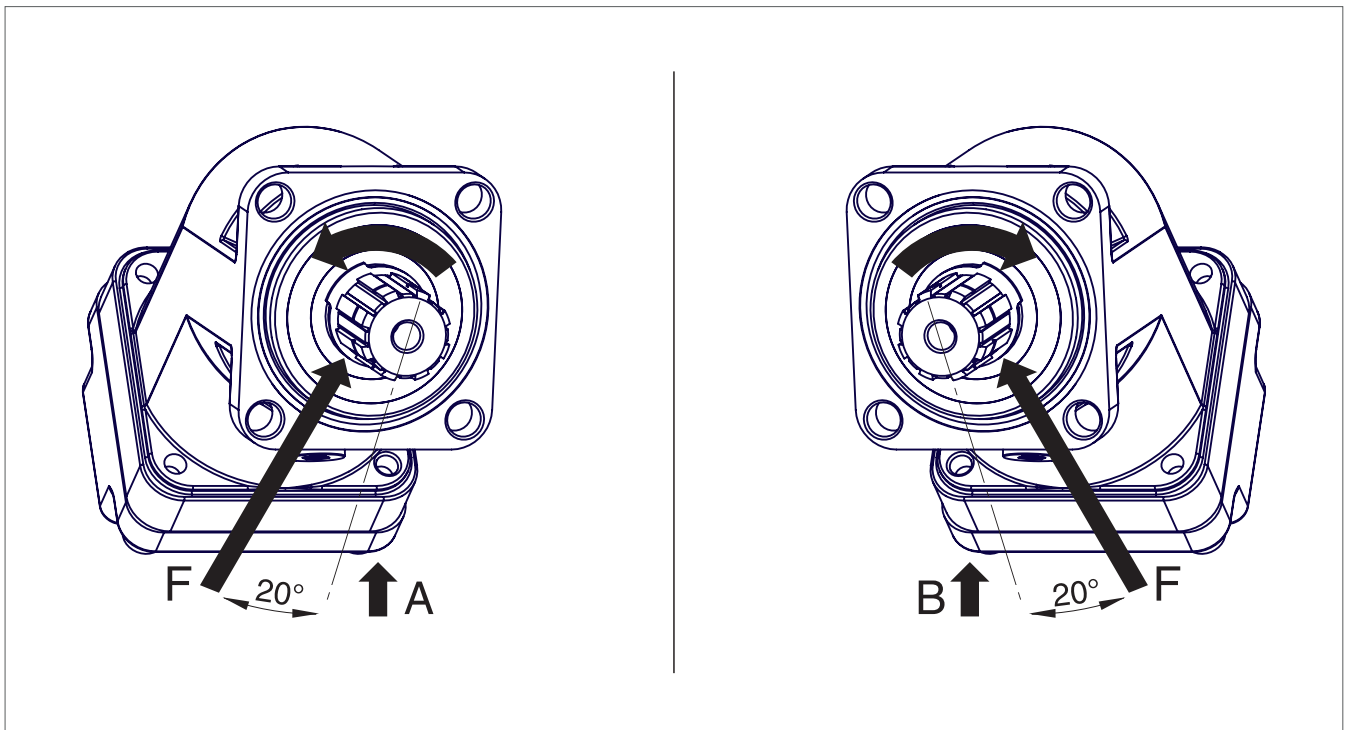

FOR USE;

Available via e-mail on request or each motor is supplied via Starting datasheet.

Formulas, Calculations, Installation Guide

Quick Calculation

Flow rate

$$Q = \frac{V_s \cdot n}{1000 \eta_v} \text{ (lpm)}$$

Torque

$$M = \frac{V_s \cdot \Delta p \cdot \eta_{mh}}{63} \text{ (Nm)}$$

Power

$$P = \frac{2\pi \cdot M \cdot n}{60000} = \frac{M \cdot n}{9549} = \frac{Q \cdot \Delta p \cdot \eta_t}{600} \text{ (kw)}$$

Speed

$$n = \frac{1000 \cdot Q \cdot \eta_v}{V_s} \text{ (lpm)}$$

- V_s = Displacement (ccm/rev.)
- Δp = Diff. pressure (bar)
- n = Speed (rpm)
- Q = Flow (lpm)
- η_v = Volumetric efficiency
- η_{mh} = Mechanical-hydraulic efficiency
- η_t = Total efficiency ($\eta_t = \eta_v \times \eta_{mh}$)

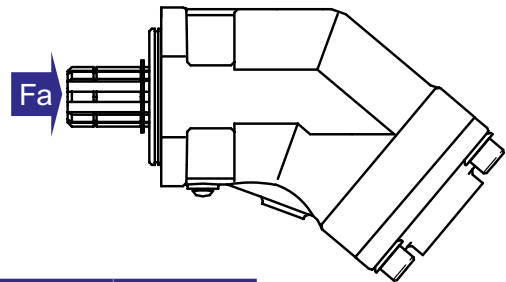

Motor model	18 cc	25 cc	32 cc	41 cc	50 cc	56, 63cc
Fa (N/bar)	20	30	30	40	40	50

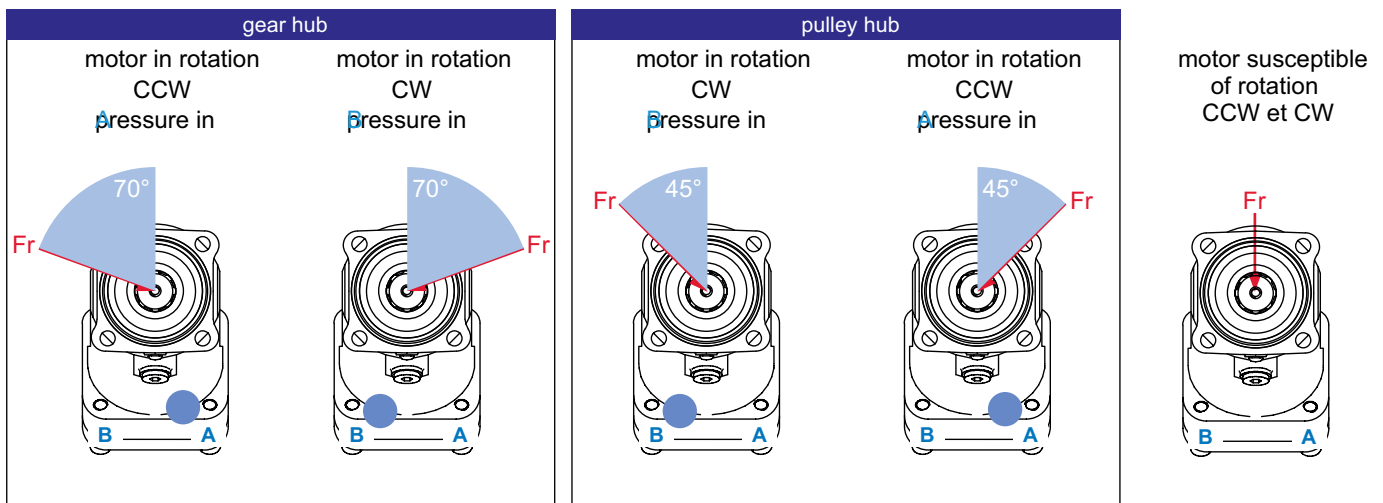

Other Advantages of DIN Flange Bent Axis Motors

- Interchangeable and Compatible with other DIN Bent Axis Motors,
- Special Designed Pistons,
- One-Piece Piston with Piston Rings,
- For use in stationary and mobile applications,
- Compact motor design and extra durable parts,
- High Operational Reliability and High Starting Torque
- Extra Warranty with Wide Service

Complete Product Range

Bent Axis Piston Motors

K2FM (DIN) Bent Axis Motor
K3FH (HYBRID) Bent Axis Motor
A2MS (SAE) Bent Axis Motor
A3MS (SAE2) Bent Axis Motor
A2FM (ISO) Bent Axis Motor
A2FE (Fixed Plugin) Bent Axis Motor
A2FE (Two Speed) Bent Axis Motor
A2FT 45 (Inline) Bent Axis Motor

Bent Axis Piston Pumps

K2FA (DIN) Bent Axis Pump
K2FH (HYBRID) Bent Axis Pump
K2FL (Aluminum) Bent Axis Pump
A2FS (SAE) Bent Axis Pump
A3FS (SAE2) Bent Axis Pump
A2FO (ISO) Bent Axis Pump
A3FO (ISO2) Bent Axis Pump
A2FP (Fixed Plugin) Bent Axis Pump

Variable Displacement Motors

AXMV Variable Piston Motor
AXMA Variable Piston Motor
AXMI Variable Piston Motor

Variable Displacement Pumps

AXVP Variable Piston Motor
AXVA Variable Piston Motor
AXVI Variable Piston Motor

Dual Flow Piston Pumps

A2FD (DIN) Dual Flow Pumps
A2FD (SAE) Dual Flow Pumps
A2PD Axial Dual Output Pumps

Axial Piston & Gear Pumps

A3PP Axial Piston Pumps
A3PH High Pressure Pumps
A2GP Gear Pumps
A2GPT Tandem Gear Pumps
A2GM Gear Motors
A2GMT Tandem Gear Motors

Valve (ByPass) (Flushing) (Cavitation)

Circulation Valve
ByPass Valve
Anti-Cavitation Valve
Flushing Valve
LS Valve
AntiShock Valve
Speed Sensor

Hydraulic Spare Parts

Suction Fittings
Couplars
Adapters
Flanges
Power Take Off
Monoblock Valve
Section Valve

Hydraulic Pumps, Motors

Bent Axis Hydraulic Piston Motors, Bent Axis Hydraulic Piston Pumps, Bent Axis Motors, Variable Displacement Piston Pumps, Variable Displacement Piston Motors, Axial Piston Pumps, High Pressure Piston Pumps, Gear Pumps, Gear Motors, Hydraulic Valve.

www.HIDRAPAC.com

Address;

HIDRAPAC HİDROLİK İÇ VE DIŞ TİC LTD ŞTİ

Address; Fevzicakmak Mah. Sıla Cad. Kobisan 3 San. Sit.
No:73 / C Karatay – Konya, PO Code; 42050, Türkiye

Phone; +90 551 111 77 44

VAT Number; 462 077 9143

www.HIDRAPAC.com

MAIL@HIDRAPAC.com

INFO@HIDRAPAC.com

Hidrapac **Store**

www.HIDRAPAC.com.tr

Hidrapac **Premium**

www.HIDRAPACHYDRAULIC.com