

A2GM Hydraulic Gear Motors -2022-

Hydraulic Gear Motors, Single Flow, High Pressure.
High Rotational Speed, High Efficiency, Slim Design.
Cast Iron Motor Body, Re-Designed in 2022.

Designation;

17cc, 22cc, 25cc, 40cc, 45cc, 50cc,
63cc, 75cc, 80cc, 100cc, 110cc, 120cc, 130cc



Hidrapac **Store**
www.HIDRAPAC.com.tr

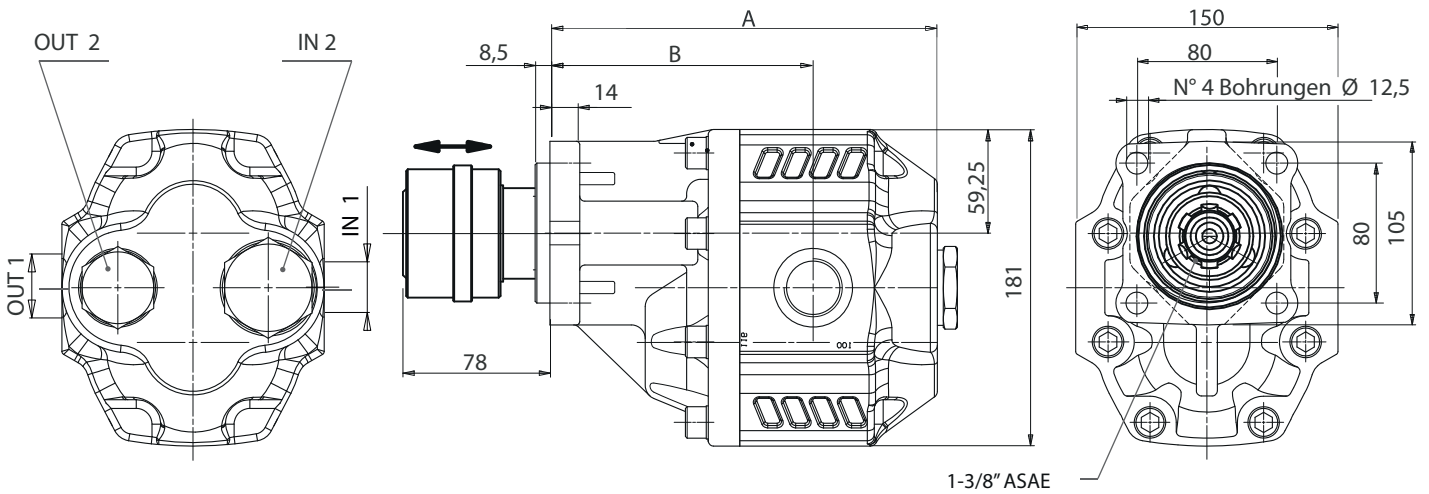

Displacement	Ordering Code		Technical Information							Dimensions				Weight in KG	
	Bi-Directional Motor Version	Bi-Directional Motor Version	P1 in bar	P2 in bar	P3 in bar	Maximum Speed	Maximum Intermitt. Peak Speed	min. Pressure	Suction Outlet 1	Suction Outlet 2	Pressure Conn. 1	Pressure Conn. 2	A in mm		B in mm
63.70	A2GM	035-900-01050	290	315	325	1800	2700	300	1"	1"	3/4"	3/4"	201.5	136.5	20
74.87	A2GM	035-900-01150	280	300	315	1800	2700	300	1"	1"	3/4"	3/4"	205.5	140.5	22
85.96	A2GM	035-900-01250	260	280	290	1800	2700	300	1-1/4"	1-1/4"	1"	1"	209.5	141	22.5
102.60	A2GM	035-900-01350	250	270	280	1800	2700	300	1-1/4"	1-1/4"	1"	1"	215.5	144.5	23
119.24	A2GM	035-900-01450	240	260	270	1500	2700	300	1-1/4"	1-1/4"	1"	1"	221.5	150.5	23.5
135.88	A2GM	035-900-01550	220	250	260	1500	2500	300	1-1/2"	1-1/2"	1"	1"	231.5	152.5	24.5
149.75	A2GM	035-900-01650	180	210	220	1500	2500	300	1-1/2"	1-1/2"	1"	1"	236.5	157.5	25

P1 = max. Pressure (100%)

P2 = max. Intermittent pressure (max. 20 Sec.)

P3 = Peak Pressure (max. 6 Sec.)

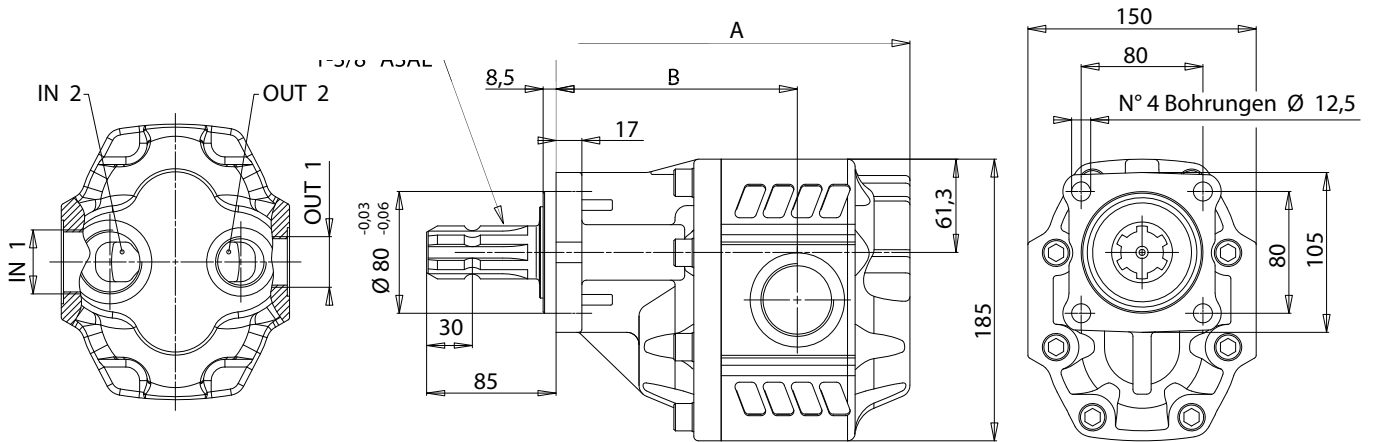

Displacement	Ordering Code		Technical Information										Dimensions		
	Bi-Directional Motor Version	Bi-Directional Motor Version	P1 in bar	P2 in bar	P3 in bar	Maximum Speed	Maximum Intermitt. Peak Speed	min. Pressure	Suction Outlet 1	Suction Outlet 2	Pressure Conn. 1	Pressure Conn. 2	A in mm	B in mm	Weight in KG
63,7	A2GM	035-909-01050	290	315	325	1800	2700	300	1"	1"	3/4"	3/4"	201,5	136,5	19
74,87	A2GM	035-909-01150	280	300	315	1800	2700	300	1"	1"	3/4"	3/4"	205,5	140,5	21
85,96	A2GM	035-909-01250	260	280	290	1800	2700	300	1-1/4"	1-1/4"	1"	1"	209,5	141	21,5
102,6	A2GM	035-909-01350	250	270	280	1800	2700	300	1-1/4"	1-1/4"	1"	1"	215,5	144,5	22
119,24	A2GM	035-909-01450	240	260	270	1500	2700	300	1-1/4"	1-1/4"	1"	1"	221,5	150,5	22,5
135,88	A2GM	035-909-01550	220	250	260	1500	2500	300	1-1/2"	1-1/2"	1"	1"	227,5	153,5	23,5
149,75	A2GM	035-909-01650	180	210	220	1500	2500	300	1-1/2"	1-1/2"	1"	1"	232,5	158,5	24

P1 = max. Pressure (100%)

P2 = max. Intermittent pressure (max. 20 Sec.)

P3 = Peak Pressure (max. 6 Sec.)

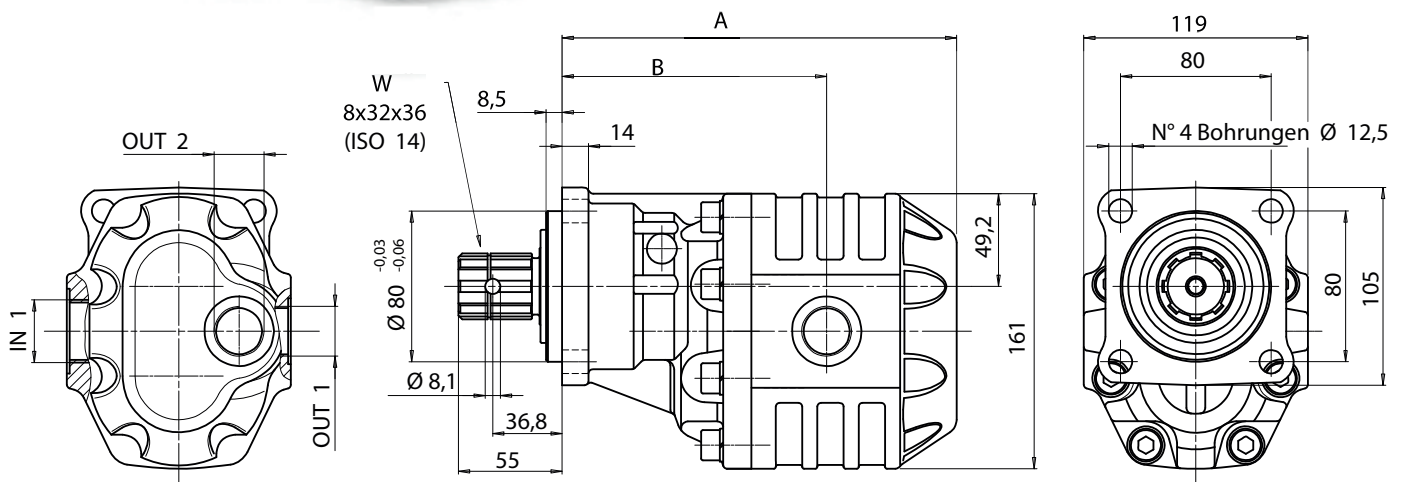

Displacement	Ordering Code		Technical Information						Dimensions					
	Bi-Directional Motor Version	Bi-Directional Motor Version	P1 in bar	P2 in bar	P3 in bar	Maximum Speed	Maximum Intermitt. Peak Speed	min. Pressure	Suction Outlet 1	Suction Outlet 2	Pressure Conn. 1	Pressure Conn. 2	A in mm	B in mm
17,04	A2GM	035-919-01050	290	315	325	2500	3000	300	1/2"	1/2"	1/2"	168,5	119,5	11
22,15	A2GM	035-919-01150	290	315	325	2500	3000	300	1/2"	1/2"	1/2"	172	121,5	11,5
26,18	A2GM	035-919-01250	290	315	325	2500	3000	300	3/4"	1/2"	1/2"	174,5	124	12
38,88	A2GM	035-919-01350	280	300	310	2200	2800	300	3/4"	3/4"	3/4"	179,5	125	13
43,12	A2GM	035-919-01450	270	290	300	2000	2500	300	3/4"	3/4"	3/4"	185,5	130	13,5
50,82	A2GM	035-919-01550	240	260	280	2000	2500	300	1"	3/4"	3/4"	190,5	130,5	14
60,06	A2GM	035-919-01650	220	240	250	1800	2000	300	1"	3/4"	3/4"	196,5	136,5	14,5
72,88	A2GM	035-919-01750	200	220	230	1600	1800	300	1"	3/4"	3/4"	204,5	135,5	15
81,08	A2GM	035-919-01850	190	210	220	1500	1800	300	1-1/4"	3/4"	3/4"	209,5	140,5	15,5
98,18	A2GM	035-919-02050	180	200	220	1500	1800	300	1-1/4"	1"	3/4"	226,5	154,5	15
122,72	A2GM	035-919-02150	160	180	200	1500	1800	300	1-1/4"	1"	3/4"	242,5	158,5	17

P1 = max. Pressure (100%)
P2 = max. Intermittent pressure (max. 20 Sec.)
P3 = Peak Pressure (max. 6 Sec.)

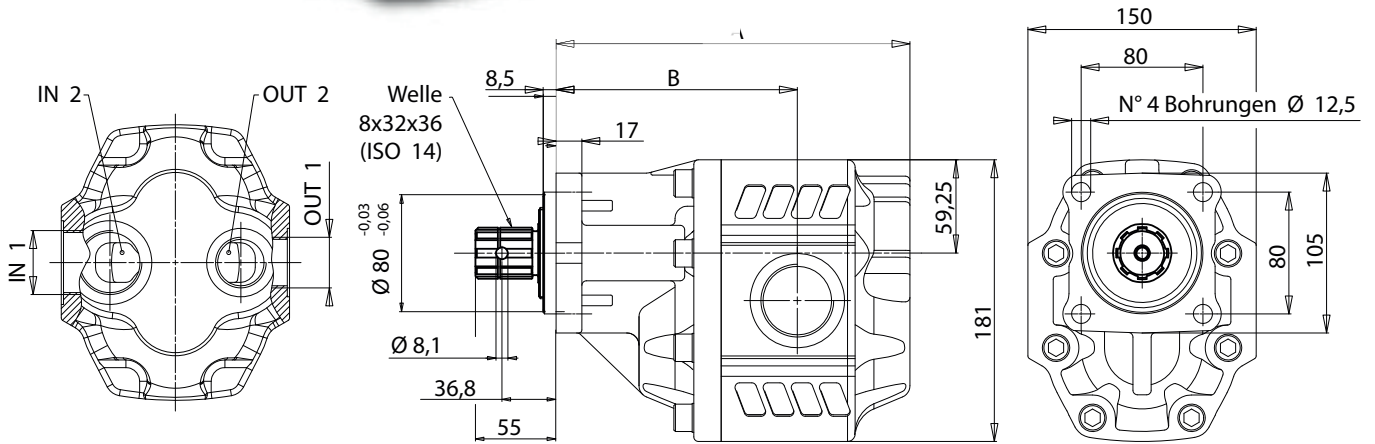

Displacement	Ordering Code		Technical Information						Dimensions						
	Bi-Directional Motor Version	Bi-Directional Motor Version	P1 in bar	P2 in bar	P3 in bar	Maximum Speed	Maximum Intermitt. Peak Speed	min. Pressure	Suction Outlet 1	Suction Outlet 2	Pressure Conn. 1	Pressure Conn. 2	A in mm	B in mm	Weight in KG
63,7	A2GM	030-929-01050	290	315	325	1800	2700	300	1"	1"	3/4"	3/4"	201,5	136,5	19
74,87	A2GM	030-929-01150	280	300	315	1800	2700	300	1"	1"	3/4"	3/4"	205,5	140,5	21
85,96	A2GM	030-929-01250	260	280	290	1800	2700	300	1-1/4"	1-1/4"	1"	1"	209,5	141	21,5
102,6	A2GM	030-929-01350	250	270	280	1800	2700	300	1-1/4"	1-1/4"	1"	1"	215,5	144,5	22
119,24	A2GM	030-929-01450	240	260	270	1500	2700	300	1-1/4"	1-1/4"	1"	1"	221,5	150,5	22,5
135,88	A2GM	030-929-01550	220	250	260	1500	2500	300	1-1/2"	1-1/2"	1"	1"	231,5	152,5	23,5
149,75	A2GM	030-929-01650	180	210	220	1500	2500	300	1-1/2"	1-1/2"	1"	1"	236,5	157,5	24

P1 = max. Pressure (100%)

P2 = max. Intermittent pressure (max. 20 Sec.)

P3 = Peak Pressure (max. 6 Sec.)

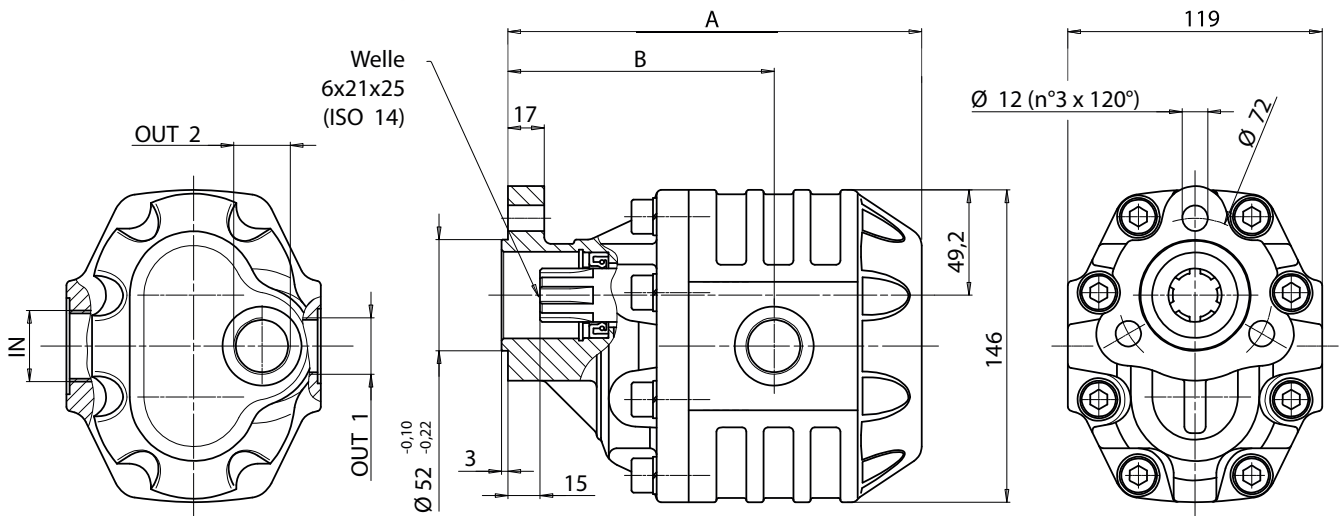

Displacement	Ordering Code		Technical Information						Dimensions					
	Bi-Directional Motor Version	Bi-Directional Motor Version	P1 in bar	P2 in bar	P3 in bar	Maximum Speed	Maximum Intermitt. Peak Speed	min. Pressure	Suction Outlet 1	Suction Outlet 2	Pressure Conn. 1	Pressure Conn. 2	A in mm	B in mm
17,04	A2GM	030-939-01050	290	315	325	2500	3000	300	1/2"	1/2"	1/2"	152,5	103,5	8,5
22,15	A2GM	030-939-01150	290	315	325	2500	3000	300	1/2"	1/2"	1/2"	156	105,5	9
26,18	A2GM	030-939-01250	290	315	325	2500	3000	300	3/4"	1/2"	1/2"	158,5	108	9,5
38,88	A2GM	030-939-01350	280	300	310	2200	2800	300	3/4"	3/4"	3/4"	163,5	109	10,5
43,12	A2GM	030-939-01450	270	290	300	2000	2500	300	3/4"	3/4"	3/4"	169,5	114	11
50,82	A2GM	030-939-01550	240	260	280	2000	2500	300	1"	3/4"	3/4"	174,5	114,5	11,5
60,06	A2GM	030-939-01650	220	240	250	1800	2000	300	1"	3/4"	3/4"	180,5	120,5	12
72,88	A2GM	030-939-01750	200	220	230	1600	1800	300	1"	3/4"	3/4"	188,5	119,5	12,5
81,08	A2GM	030-939-01850	190	210	220	1500	1800	300	1-1/4"	3/4"	3/4"	193,5	124,5	13
90,43	A2GM	030-939-01950	180	200	220	1500	1800	300	1-1/4"	1"	3/4"	204,5	132,5	13,5
98,18	A2GM	030-939-02050	180	200	220	1500	1800	300	1-1/4"	1"	3/4"	210,5	138,5	14
122,72	A2GM	030-939-02150	160	180	200	1500	1800	300	1-1/4"	1"	3/4"	226,5	142,5	16

P1 = max. Pressure (100%)

P2 = max. Intermittent pressure (max. 20 Sec.)

P3 = Peak Pressure (max. 6 Sec.)

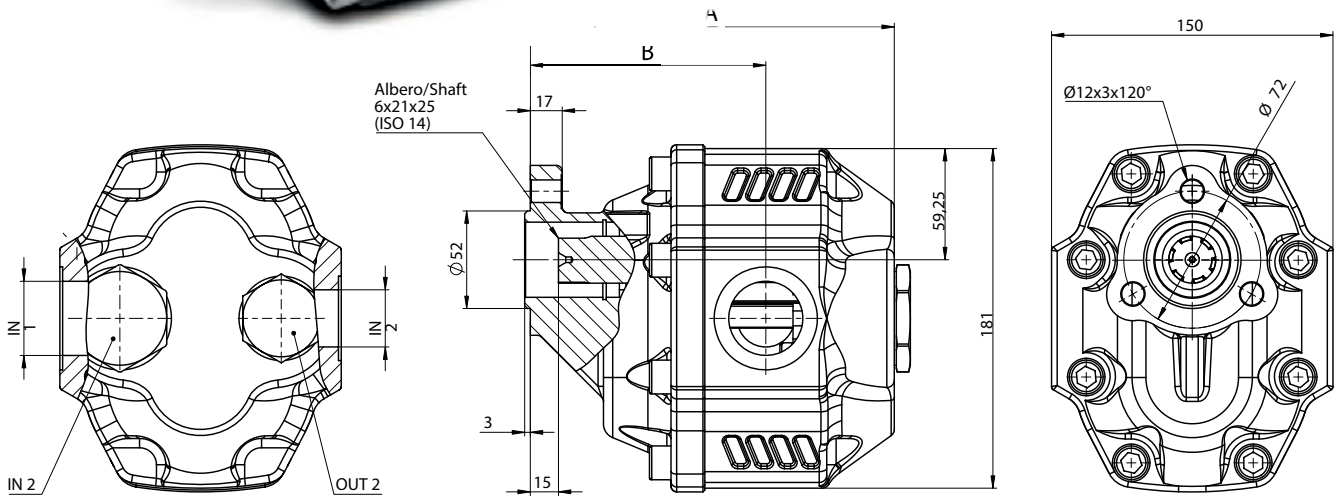

Displacement	Ordering Code		Technical Information							Dimensions					
	Bi-Directional Motor Version	Bi-Directional Motor Version	P1 in bar	P2 in bar	P3 in bar	Maximum Speed	Maximum Intermitt. Peak Speed	min. Pressure	Suction Outlet 1	Suction Outlet 2	Pressure Conn. 1	Pressure Conn. 2	A in mm	B in mm	Weight in KG
63,7	A2GM	030-949-01050	290	315	325	1800	2700	300	1"	1"	3/4"	3/4"	186	121	17,5
74,87	A2GM	030-949-01150	280	300	315	1800	2700	300	1"	1"	3/4"	3/4"	190	125	18,5
85,96	A2GM	030-949-01250	260	280	290	1800	2700	300	1-1/4"	1-1/4"	1"	1"	194	125,5	19
102,6	A2GM	030-949-01350	250	270	280	1800	2700	300	1-1/4"	1-1/4"	1"	1"	200	129	19,5
119,24	A2GM	030-949-01450	240	260	270	1500	2700	300	1-1/4"	1-1/4"	1"	1"	206	135	20
135,88	A2GM	030-949-01550	220	250	260	1500	2500	300	1-1/2"	1-1/2"	1"	1"	216	137	21
149,75	A2GM	030-949-01650	180	210	220	1500	2500	300	1-1/2"	1-1/2"	1"	1"	221	142	21,5

P1 = max. Pressure (100%)
 P2 = max. Intermittent pressure (max. 20 Sec.)
 P3 = Peak Pressure (max. 6 Sec.)

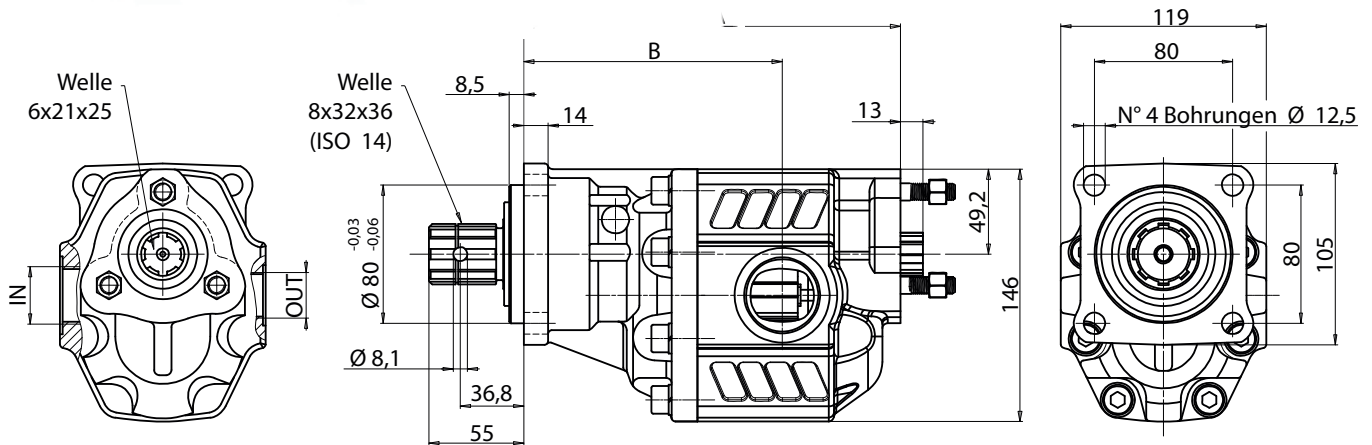

Displacement	Ordering Code		Technical Information					Dimensions					Weight in KG
	Bi-Directional Motor Version	Bi-Directional Motor Version	P1 in bar	P2 in bar	P3 in bar	Maximum Speed	Maximum Intermitt. Peak Speed	min. Pressure	Suction Outlet 1	Suction Outlet 2	Pressure Conn. 1	Pressure Conn. 2	
17,04	A2GM	035-959-01050	290	315	325	2500	3000	300	1/2"	1/2"	180	119	10,6
22,15	A2GM	035-959-01150	290	315	325	2500	3000	300	1/2"	1/2"	183,5	121,5	11
26,18	A2GM	035-959-01250	290	315	325	2500	3000	300	1/2"	1/2"	186	124	11,5
33,88	A2GM	035-959-01350	280	300	310	2200	2800	300	3/4"	3/4"	191	124	12,5
43,12	A2GM	035-959-01450	270	290	300	2000	2500	300	3/4"	3/4"	197	130	13
50,82	A2GM	035-959-01550	240	260	280	2000	2500	300	3/4"	3/4"	202	130,5	13,5
60,06	A2GM	035-959-01650	220	240	250	1800	2000	300	1"	1"	208	136,5	14
72,88	A2GM	035-959-01750	200	220	230	1600	1800	300	1"	1"	216	135,5	14,5
81,08	A2GM	035-959-01850	190	210	220	1500	1800	300	1-1/4"	1-1/4"	221	142,5	14,9

P1 = max. Pressure (100%)
 P2 = max. Intermittent pressure (max. 20 Sec.)
 P3 = Peak Pressure (max. 6 Sec.)

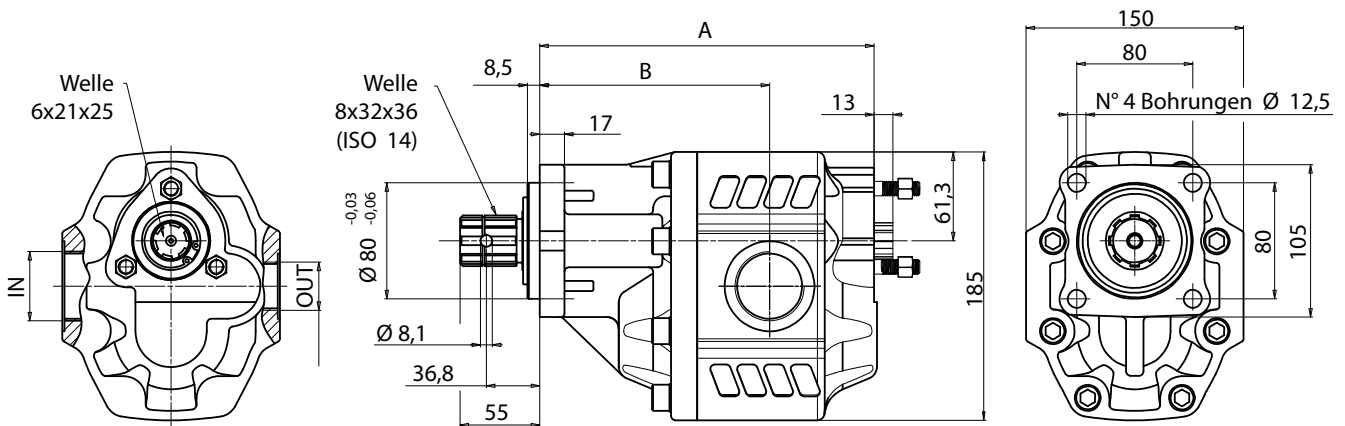
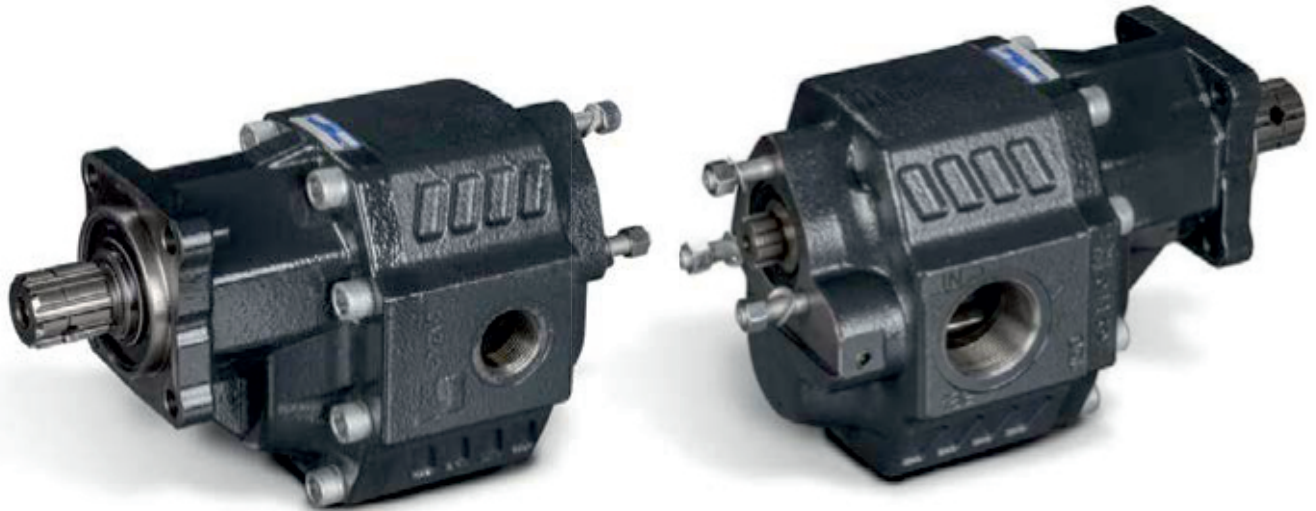

Displacement	Ordering Code		Technical Information						Dimensions					
	Bi-Directional Motor Version	Bi-Directional Motor Version	P1 in bar	P2 in bar	P3 in bar	Maximum Speed	Maximum Intermitt. Peak Speed	min. Pressure	Suction Outlet 1	Suction Outlet 2	Pressure Conn. 1	Pressure Conn. 2	A in mm	B in mm
63,7	A2GM	035-969-01050	290	315	325	1800	2700	300	1"	3/4"	199,5	136,5	20,1	
74,87	A2GM	035-969-01150	280	300	315	1800	2700	300	1"	3/4"	203,5	140,5	20,7	
85,96	A2GM	035-969-01250	260	280	290	1800	2700	300	1-1/4"	1"	207,5	141	20,9	
102,6	A2GM	035-969-01350	250	270	280	1800	2700	300	1-1/4"	1"	213,5	144,5	21,5	
119,24	A2GM	035-969-01450	240	260	270	1500	2700	300	1-1/4"	1"	219,5	150,5	22	
135,88	A2GM	035-969-01550	220	250	260	1500	2500	300	1-1/2"	1"	225,5	153,5	22,8	
149,75	A2GM	035-969-01650	180	210	220	1500	2500	300	1-1/2"	1"	230,5	158,8	24,1	

P1 = max. Pressure (100%)
 P2 = max. Intermittent pressure (max. 20 Sec.)
 P3 = Peak Pressure (max. 6 Sec.)

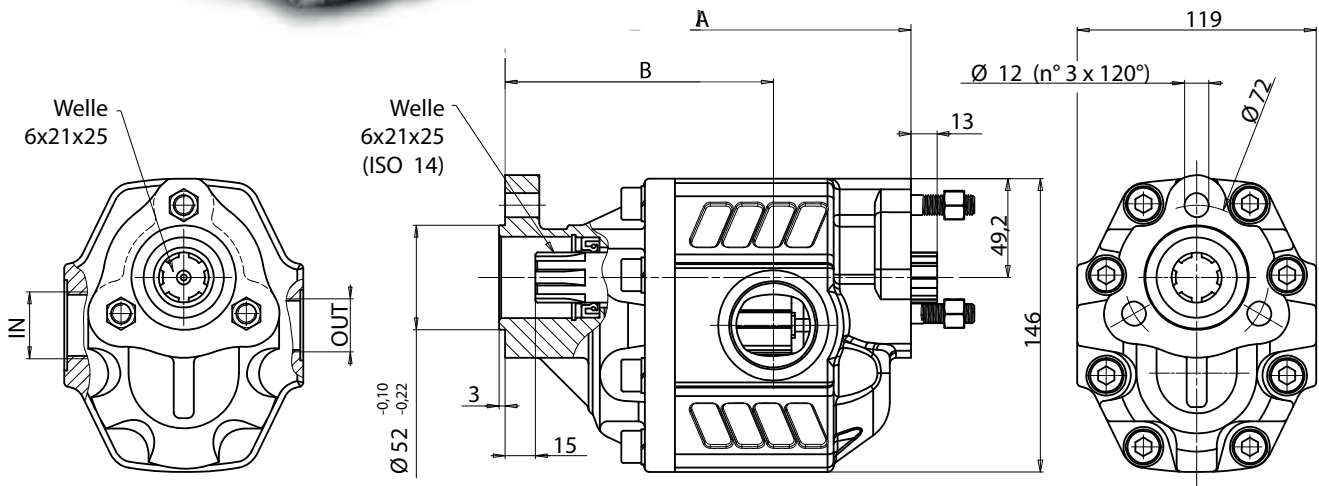

Displacement	Ordering Code		Technical Information						Dimensions					
	Bi-Directional Motor Version	Bi-Directional Motor Version	P1 in bar	P2 in bar	P3 in bar	Maximum Speed	Maximum Intermitt. Peak Speed	min. Pressure	Suction Outlet 1	Suction Outlet 2	Pressure Conn. 1	Pressure Conn. 2	A in mm	B in mm
17,04	A2GM	035-979-01050	290	315	325	2500	3000	300	1/2"	1/2"	164	103	9,6	
22,15	A2GM	035-979-01150	290	315	325	2500	3000	300	1/2"	1/2"	167,5	105,5	9,8	
26,18	A2GM	035-979-01250	290	315	325	2500	3000	300	1/2"	1/2"	170	108	10,1	
33,88	A2GM	035-979-01350	280	300	310	2200	2800	300	3/4"	3/4"	175	108	10,5	
43,12	A2GM	035-979-01450	270	290	300	2000	2500	300	3/4"	3/4"	181	114	11,02	
50,82	A2GM	035-979-01550	240	260	280	2000	2500	300	3/4"	3/4"	186	114,5	11,3	
60,06	A2GM	035-979-01650	220	240	250	1800	2000	300	1"	1"	192	120,5	11,8	
72,88	A2GM	035-979-01750	200	220	230	1600	1800	300	1"	1"	200	119,5	12,4	
81,08	A2GM	035-979-01850	190	210	220	1500	1800	300	1-1/4"	1-1/4"	205	126,5	12,6	

P1 = max. Pressure (100%)
P2 = max. Intermittent pressure (max. 20 Sec.)
P3 = Peak Pressure (max. 6 Sec.)

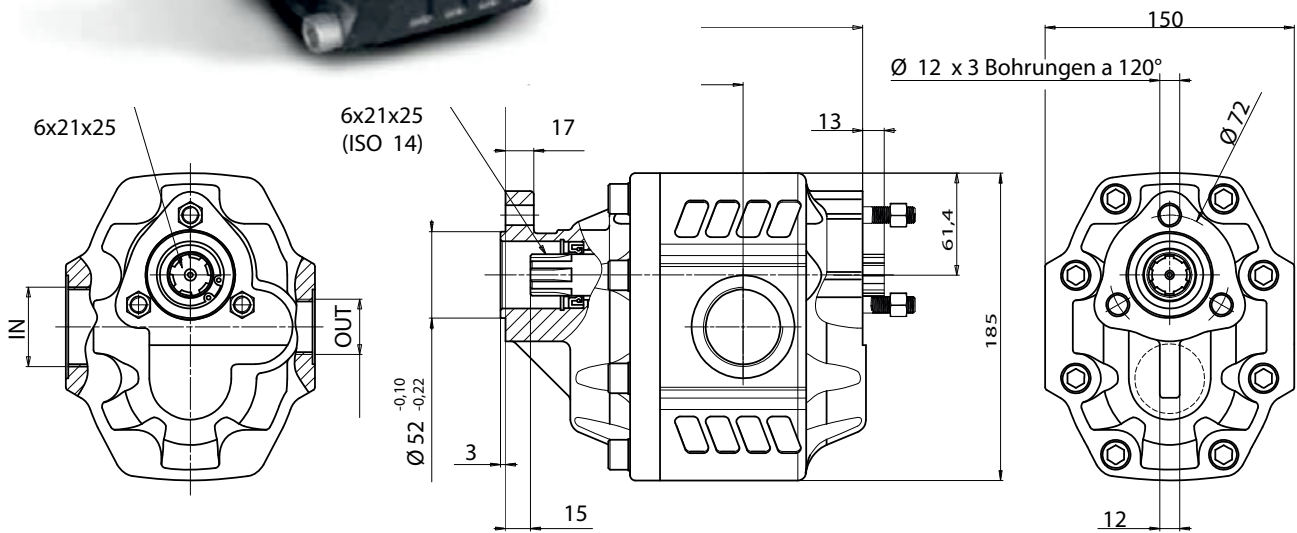
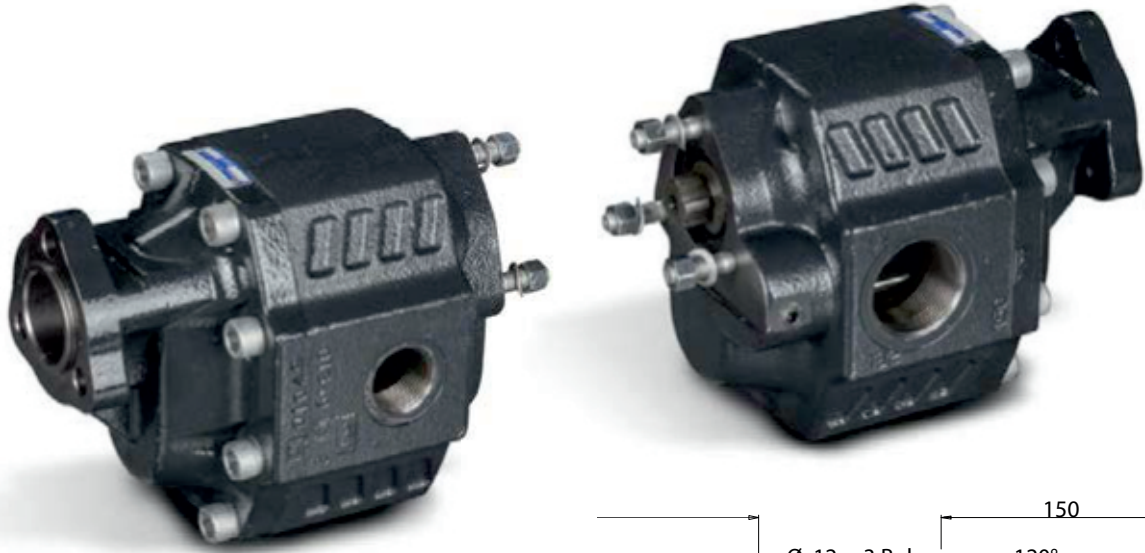

Displacement	Ordering Code		Technical Information						Dimensions					
	Bi-Directional Motor Version	Bi-Directional Motor Version	P1 in bar	P2 in bar	P3 in bar	Maximum Speed	Maximum Intermitt. Peak Speed	min. Pressure	Suction Outlet 1	Suction Outlet 2	Pressure Conn. 1	Pressure Conn. 2	A in mm	B in mm
63,7	A2GM	035-989-01050	290	315	325	1800	2700	300	1"	3/4"	184	121	17	
74,87	A2GM	035-989-01150	280	300	315	1800	2700	300	1"	3/4"	188	125	18	
85,96	A2GM	035-989-01250	260	280	290	1800	2700	300	1-1/4"	1"	192	125,5	18,5	
102,6	A2GM	035-989-01350	250	270	280	1800	2700	300	1-1/4"	1"	198	129	19	
119,24	A2GM	035-989-01450	240	260	270	1500	2700	300	1-1/4"	1"	204	135	19,5	
135,88	A2GM	035-989-01550	220	250	260	1500	2500	300	1-1/2"	1"	210	138	20,5	
149,75	A2GM	035-989-01650	180	210	220	1500	2500	300	1-1/2"	1"	215	143	21	

P1 = max. Pressure (100%)

P2 = max. Intermittent pressure (max. 20 Sec.)

P3 = Peak Pressure (max. 6 Sec.)

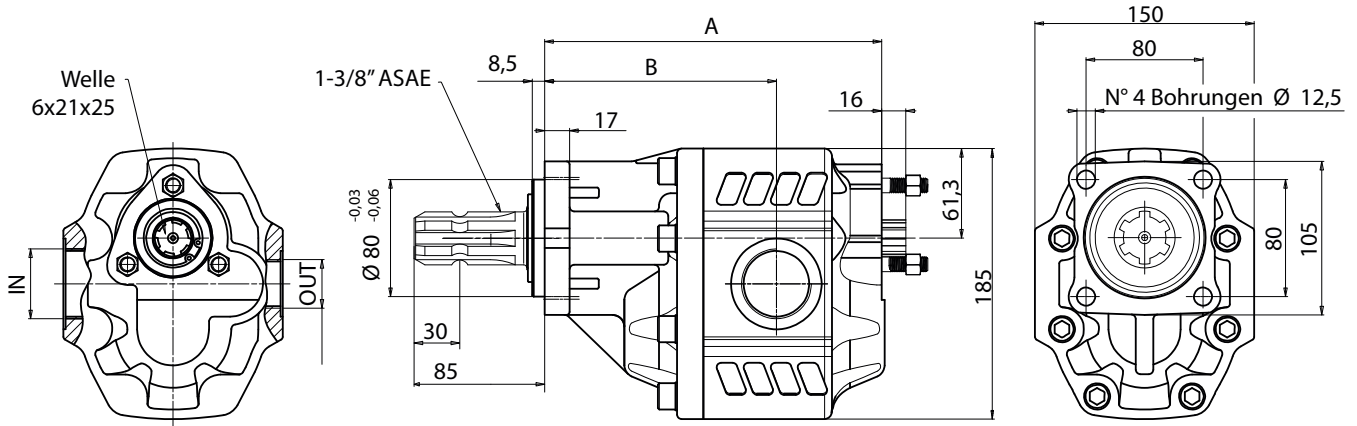
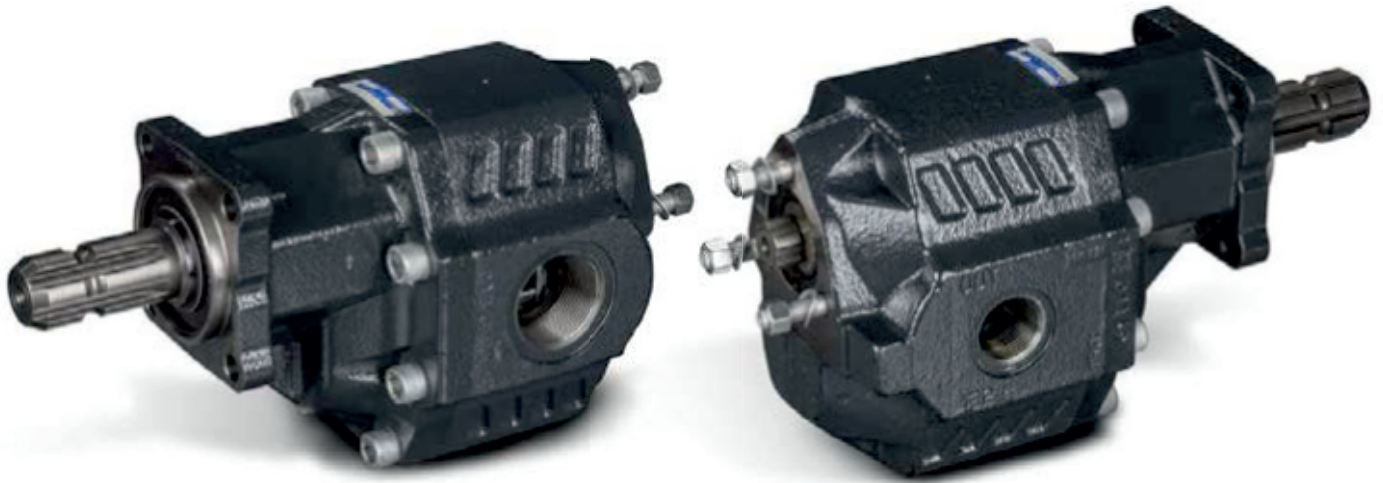

Displacement	Ordering Code		Technical Information						Dimensions					
	Bi-Directional Motor Version	Bi-Directional Motor Version	P1 in bar	P2 in bar	P3 in bar	Maximum Speed	Maximum Intermitt. Peak Speed	min. Pressure	Suction Outlet 1	Suction Outlet 2	Pressure Conn. 1	Pressure Conn. 2	A in mm	B in mm
63,7	A2GM	035-999-01050	290	315	325	1800	2700	2700	300	1"	3/4"	199,5	136,5	
74,87	A2GM	035-999-01150	280	300	315	1800	2700	2700	300	1"	3/4"	203,5	140,5	
85,96	A2GM	035-999-01250	260	280	290	1800	2700	2700	300	1-1/4"	1"	207,5	141	
102,6	A2GM	035-999-01350	250	270	280	1800	2700	2700	300	1-1/4"	1"	213,5	144,5	
119,24	A2GM	035-999-01450	240	260	270	1500	2700	2700	300	1-1/4"	1"	219,5	150,5	
135,88	A2GM	035-999-01550	220	250	260	1500	2500	2500	300	1-1/2"	1"	225,5	153,5	
149,75	A2GM	035-999-01650	180	210	220	1500	2500	2500	300	1-1/2"	1"	230,5	158,5	

P1 = max. Pressure (100%)

P2 = max. Intermittent pressure (max. 20 Sec.)

P3 = Peak Pressure (max. 6 Sec.)

Complete Product Range

Bent Axis Piston Motors

K2FM (DIN) Bent Axis Motor
K3FH (HYBRID) Bent Axis Motor
A2MS (SAE) Bent Axis Motor
A3MS (SAE2) Bent Axis Motor
A2FM (ISO) Bent Axis Motor
A2FE (Fixed Plugin) Bent Axis Motor
A2FE (Two Speed) Bent Axis Motor
A2FT 45 (Inline) Bent Axis Motor

Bent Axis Piston Pumps

K2FA (DIN) Bent Axis Pump
K2FH (HYBRID) Bent Axis Pump
K2FL (Aluminum) Bent Axis Pump
A2FS (SAE) Bent Axis Pump
A3FS (SAE2) Bent Axis Pump
A2FO (ISO) Bent Axis Pump
A3FO (ISO2) Bent Axis Pump
A2FP (Fixed Plugin) Bent Axis Pump

Variable Displacement Motors

AXMV Variable Piston Motor
AXMA Variable Piston Motor
AXMI Variable Piston Motor

Variable Displacement Pumps

AXVP Variable Piston Motor
AXVA Variable Piston Motor
AXVI Variable Piston Motor

Dual Flow Piston Pumps

A2FD (DIN) Dual Flow Pumps
A2FD (SAE) Dual Flow Pumps
A2PD Axial Dual Output Pumps

Axial Piston & Gear Pumps

A3PP Axial Piston Pumps
A3PH High Pressure Pumps
A2GP Gear Pumps
A2GPT Tandem Gear Pumps
A2GM Gear Motors
A2GMT Tandem Gear Motors

Valve (ByPass) (Flushing) (Cavitation)

Circulation Valve
ByPass Valve
Anti-Cavitation Valve
Flushing Valve
LS Valve
AntiShock Valve
Speed Sensor

Hydraulic Spare Parts

Suction Fittings
Couplars
Adapters
Flanges
Power Take Off
Monoblock Valve
Section Valve

Hydraulic Motors, Motors

Bent Axis Hydraulic Piston Motors, Bent Axis Hydraulic Piston Motors, Dual Flow Motors, Variable Displacement Piston Motors, Variable Displacement Piston Motors, Axial Piston Motors, High Pressure Piston Motors, Gear Motors, Gear Motors, Hydraulic Valve.

www.HIDRAPAC.com

Address;

HIDRAPAC HİDROLİK İÇ VE DIŞ TİC LTD ŞTİ

Address; Fevzicakmak Mah. Sıla Cad. Kobisan 3 San. Sit.
No:73 / C Karatay – Konya, PO Code; 42050, Türkiye

Phone; +90 551 111 77 44

VAT Number; 462 077 9143

www.HIDRAPAC.com

MAIL@HIDRAPAC.com

INFO@HIDRAPAC.com

Hidrapac **Store**

www.HIDRAPAC.com.tr

Hidrapac **Premium**

www.HIDRAPACHYDRAULIC.com